



# **Our Favourite Colony Games**

Fylde District Beavers

Compiled & Edited by  
Kevin Jacomb  
DBSL

## Fylde District Favourite Games

This booklet describes the favourite games of Beaver Colonies in the Fylde District. They are therefore well tried and tested and can be recommended to others.

Thanks go to the Colonies who provided write-ups of the games. They are noted after the game's title, as follows :

1 C	1 <sup>st</sup> Clifton
1 K&W	1 <sup>st</sup> Kirkham & Wesham
1 W	1 <sup>st</sup> Warton
1 WG	1 <sup>st</sup> Wrea Green
2 F	2 <sup>nd</sup> Freckleton
2 K	2 <sup>nd</sup> Kirkham
1 LSA	1st Lytham St. Annes
4 LSA	4 <sup>th</sup> “ “ “
7 LSA	7 <sup>th</sup> “ “ “
8 LSA	8 <sup>th</sup> “ “ “
15 LSA	15 <sup>th</sup> “ “ “
17 LSA	17 <sup>th</sup> “ “ “



that number run to their chair, stand on it and throw a beanbag at the skittle to knock it down. They retrieve it if they miss and try again. Play for fun or for points.

Link-Up Tag            1 LSA

Equipment :     none

As a Beaver is touched they join hands and chase the remainder until everyone is caught.

---

Stuck in the Mud / Scarecrow Tig / Lamp posts            1 LSA

Equipment :     none

One or two Beavers are "it". They tig the others who then stand with their legs apart and arms stretched out to the side. Beavers can free them by running under their arm or by crawling under their legs.

---

Witches Tig                            1C

Equipment :     none

One Beavers is "on" or the "witch". All the Beavers run round the room with the witch tiggig anyone he can catch. When caught the Beaver must stand with legs apart. He can then be freed by any Beaver (other than the witch) crawling through his legs.

*Change the witch regularly and consider having two witches. A fast, furious game. In fact it looks utter chaos but the Beavers seem to know what they are doing and more importantly enjoy it!*

---

Dragon's Tails                        7 LSA

Equipment :     Strips of material for tails

Strips of material are tucked in the back of the Beavers' waistband, hanging down like a tail. Two Beavers are appointed to chase the "dragons" and catch their tails. When the tails are taken, the "dragon" is "out". The game carries on until all "dragons" are caught.

---

Bingo                                1 WG

Equipment :     20 large pieces of square card, bag, small pieces of paper numbered & folded and placed in the bag

Cut out 20 large pieces of square card and number them 1 to 20 (or however many Beavers you have). Lay them out randomly on the floor. Beavers walk round. Leader shouts "BINGO". Beavers each run and stand on a card - only

one allowed per card. Someone else pulls out of the bag a number. Whatever number is called, that Beaver standing on the number is "out". Proceed until everyone is out.

*To speed it up, you can call out two or more numbers at once.*

---

### Lucky Number Dice Game                      1 K&W

Equipment :        Chalk, whistle, dice

Number 6 bases around the room. Beavers run around - Leader has back to room. Leader blows whistle and the Beavers then have to choose which number (base) they want to stay at. When they have all decided, the Leader turns around and throws the dice. Whichever number the dice lands on - whoever is on that base is "out". The game continues until the last man is "out".

Variations                                      8 LSA, 2K

- *Name bases after the theme of the evening e.g. football teams, transport types - a good game which can be used for anything*
  - *Pick number out of a bag - numbered/named bottle tops, corks, paper pieces make good nameplates*
  - *Leave Beavers "out" permanently or just for one turn*
- 

### Beaver under the Blanket                      2 K

Equipment :        Blanket, whistle

Beavers run round the room. Leader blows the whistle and all Beavers crouch down on the floor and close their eyes and tuck themselves into as small a bundle as they can. Leader covers one Beaver up with the blanket. Leader blows whistle. Beavers have to guess who is under the blanket. Point for the correct guesser.

*An excellent game for getting everyone quiet - until they start guessing , when it becomes bedlam. Beavers shout and scream that it's someone who is actually stood next to them but they don't see. They tend to be pretty hopeless at guessing - even if you ask them to think first if they can see everyone in their own lodge. They have an instinctive and unhelpful urge to crowd closely round the covered Beaver.*

Variations

- *Put a Leader under the blanket*
  - *Turn the lights out (or nearly so)*
- 

### Guess a Minute                                      2 K

Equipment :        Watch, whistle

Beavers run round the room. Leader blows the whistle and all Beavers crouch down on the floor and close their eyes and tuck themselves into as small a bundle as they can. They must not look at their own, or anyone else's, watch. When they think that a minute has passed since the Leader blew the whistle, they stand up quietly. When everyone has stood up (or when the Leader asks the remainder to stand) the Leader announces the name of the Beaver who correctly guessed the minute, or came closest to it.

*An excellent game for getting everyone quiet, particularly after energetic and noisy games. Can be repeated several times. Guess an hour would be a dream. Hide the clock!*

---

## Squirrels                      2 K

Equipment :        4 chairs, 6-8 beanbags, whistle

Chairs are placed at the corners of an imaginary square, facing towards the square's centre. Leader reads out the rules. Beavers are put into 4 teams. Each team is allocated a chair and stand in a line behind it. Each Beaver in the team is numbered off, starting with Number 1 nearest the chair. If teams are unequal, some Beavers have more than one number. The Leader throws 4 beanbags into the centre of the square and calls out a number. Beavers with that number place one hand behind their back, holding the top of their trousers, and run to get a beanbag and put it onto their team's chair. The winner is the first Beaver to get three beanbags on his chair. Beavers can only carry one beanbag at any time and can steal a beanbag from another team's chair. No one is allowed to touch the chair. If a beanbag is thrown to a chair and falls off, it is thrown into the middle. The Leader throws the 5<sup>th</sup>, 6<sup>th</sup>, ... beanbags into the middle whenever they want

*Fast and furious game. Beavers find it irresistible to touch the chair and to put fallen beanbags onto it. The beanbags represent nuts collected by the squirrels.*

### Variations

- Call out two or three numbers at a time
  - Include Leaders in the teams - it can, however, kill them!
- 

## Relay Races                      2 K

Equipment :        As required - beanbags, tables, chairs, hula hoops

Beavers are placed into teams and each team sits in a line at the end of the room beside other teams. Leader blows the whistle and each member of the team runs (or whatever task is given by the Leader) to the opposite end of the room and returns to tag the next member who repeats the task. When the whole team has "been" they sit in a straight line with arms folded and perfectly quiet. First team to finish wins.

*Easy to get into a rut with the same relay tasks each week. Try a variety such as :*

- Running forwards/backwards, hopping, crawling on tummies/back, run with hands joined behind their legs or clutching their ankles
- Under/over chairs & tables, through hoops
- Run keeping a balloon in the air by blowing or patting

## Fylde District Favourite Games

- *Balance/carry items such as a beanbag on the head, ball & spoon, ball under the chin*
- *Pass objects along the team e.g. a ball under the legs, over the head alternately*
- *Use paper plates as stepping stones to move along on*
- *Dress up relay e.g. run up and put successively wellies, jacket, scarf, gloves, hat,... on a Beaver or a Leader*
- *Join up successively until the whole team is racing with hands joined*

*A popular way to end each week's programme. Stress how to finish and that the fastest team to run (or whatever) is not necessarily the winner unless they are in a straight line with arms folded and perfectly quiet.*

---

### Hit below the Knee            2 K

Equipment :     Sponge ball

Chalk a circle on the floor. Beavers have to stay within the circle and avoid being hit below the knee by the Leaders who throw the sponge ball at their legs. When they are hit, or they step outside the circle, they are out. The last Beaver in wins.

#### Variation

- Use two or more balls.
- 

### In the Pond / Riverbanks            2K, 15 LSA

A large circle is chalked on the floor. The inside is the Pond, the outside the Bank. If the Leader calls out "In the Pond", the Beavers have to jump into the middle, provided they are outside the circle. If they are already inside and they move, they are 'out'. If he shouts "On the Bank", they have to jump outside the circle, provided they are already inside. If they are already outside and they move, they are 'out'. The Leader will try to catch them out by calling "On the Pond" or "In the Bank", in which case any Beaver who moves is 'out'. The last Beaver wins. The last 1 (or 2) Beavers to do the correct action is 'out', as is anyone taking too long to move.

*Can also be played with two long parallel lines about 1 metre apart which divide the "River"(in between the lines) from the "Bank". Calls are then "In the River", "On the Bank".*

---

### Mr Sit and Mr Stand            17 LSA

Equipment :     Story sheet

*The Beavers do the actions - sit, stand, lie - when they hear those words mentioned. Ideal for a 2 minute gap-filler. It helps to improve their listening powers.*

'Mr Sit and Mr Stand were friends who could face almost any situation with complete understanding. Mr Sit was invited to stand as parliamentary candidate for Sittingbourne and his friend Mr Stand viewed the situation with considerable understanding. As Mr Sit said, "If I stand for Sittingbourne, it is on the understanding that, if elected, I shall sit in the House". Mr Stand said, "If you wish to sit in the House, I will not stand in your way in order that you can stand for Sittingbourne. I quite understand the situation and that is no lie" After the election, Mr Sit and Mr Stand went aboard Mr Sit's yacht which was lying in the harbour. The party was completed by Mrs Stand and Mrs Sit with their sons Standly and Sitney. When dinner was served in the saloon of the yacht, Mr Stand sat with Mrs Sit and Mrs Stand sat with Mr Sit. Altogether it was a very understanding situation and there perhaps we ought to let the matter lie.'

---

## Rising Circle            15 LSA

Equipment :     none

The Beavers sit in a circle, cross legged, with their hands around the shoulders of the two Beavers either side of them. When the Leader says so, they try to rise without breaking their hold.

---

## Story Corners            17 LSA

Equipment :     none

The Leader sets an imaginary scene with each corner of the room being something different, then he tells a simple story which the Beavers have to act out as best they can. They have to listen very carefully, as the differences between some of the 'corners' can be very subtle.

The corners might, for example, be 'sleeping area', 'dining area', 'tent', 'under the stars'. "It's a nice warm night" (Beavers lie in the 'under the stars' corner)... "It suddenly starts raining" (Beavers rush to the 'tent').. etc.

*An excellent game for practising miming and improving listening skills. The Beavers enjoy it most when the story involves lots of moving around and, of course, lots of sound effects! It can be as short as 5 minutes, but has been played for 40 minutes without anyone getting fed up. Make up the story as you go along.*

---

## Ladders                    2 F

Equipment :     none

Game layout :

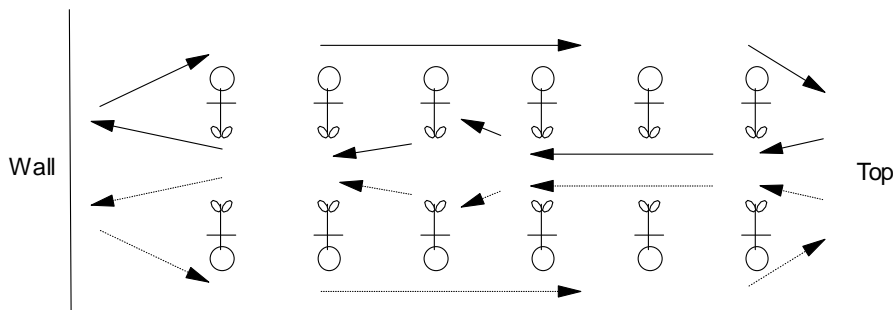



The Beavers sit in pairs on the floor facing each other with their feet touching. They form the rungs of a ladder. Each pair is numbered off from one end. The Leader calls a number and the Beavers with that number have to get up and carefully step over the rungs of the ladder (i.e. other Beavers' legs), touch the wall, run down the outside of the ladder (on their own side) to the top and then down the ladder to their places. It is a race between the pair; the first one back in his place wins.

Variations :      **Story Ladders**      **2F**

Equipment :      Story book

Each pair is given a character / part in a story. The Leader reads out the story and every time a pair hears their part mentioned they race as outlined above.

*This variation helps to improve the Beavers' listening skills and holds their attention better than the normal version. Make sure that each part features more than once. Try more than one pair racing at the same time. You will need to spend time emphasizing the route that each side takes. The younger Beavers, in particular, tend to want to run down the same side of the ladder. Also stress that Beavers must keep their legs straight out, touching, still, and on the floor - otherwise injuries can result as Beavers trip or stand on legs.*

Variation :                      **1 WG**

- Mathematical ladders – call out a sum e.g. “2 plus 3” – the pair numbered 5 race.

**Murder in the Dark**                      **15 LSA**

---

Equipment :      none

One Lodge is nominated as the team of Detectives and is sent out of the room. Everyone else stands anywhere in the room, perfectly still. The Detectives are then called in and look at where everyone is standing, and are then sent out of the room again. The Leader nominates one Beaver as the Murderer. The Murderer then stabs (pats) one Beaver that he chooses and this Beaver lies on the floor dead. The Murderer then stands wherever he likes. The Detectives are then called back in and, acting as a Team, have to identify one Beaver who they think is the Murderer. If they guess wrong, they leave the room, and the Murderer stabs another Beaver, then stands anywhere he likes. The Detectives are called back in.... (etc).

Once the Detectives have correctly identified the Murderer, another Lodge takes on the role of Detectives.

*This is an excellent test of observation and encourages teamwork among the Detectives. This teamwork should be emphasised by the Leader, pointing out that the Team can only make one guess after each murder.*

---

**Hunt the Woggle**                      **15 LSA**

Equipment :      Woggle threaded on a very large circle of string (large enough for all the Beavers to hold it side-by-side in a large circle)

The Beavers stand in a circle facing inwards, holding the circle of string in each hand. One Beaver is chosen by the Leader and goes and stands in the middle of the circle, and is told to close his eyes. The woggle is then moved around the string from Beaver to Beaver. As each Beaver gets the woggle passed to him, he hides it under one of his hands, passes it to under his other hand, then to the next Beaver. After a few seconds, the Beaver in the middle is told

to start looking and he has to try and identify who has the wobble as it is continuously passed around the circle. Each Beaver tries to make out he has it by clenching his fists and seeming to be passing it. When the Beaver in the middle has guessed correctly - or has guessed enough times - he changes places with the Beaver who has the wobble.

Rhubarb

15 LSA

Equipment : none

The Beavers sit in a circle with a Leader in the middle. The Leader approaches each Beaver, looking him in the eye, and asks him a personal question (examples below) to which he must reply every time “Rhubarb”. If he smiles or gives the wrong answer he is ‘out’.

Questions might include :

- What makes you grow so tall?
- What makes you laugh?
- What did you have for dinner / breakfast / tea?

Cat and Mouse

2 F

Equipment : none

Game layout :

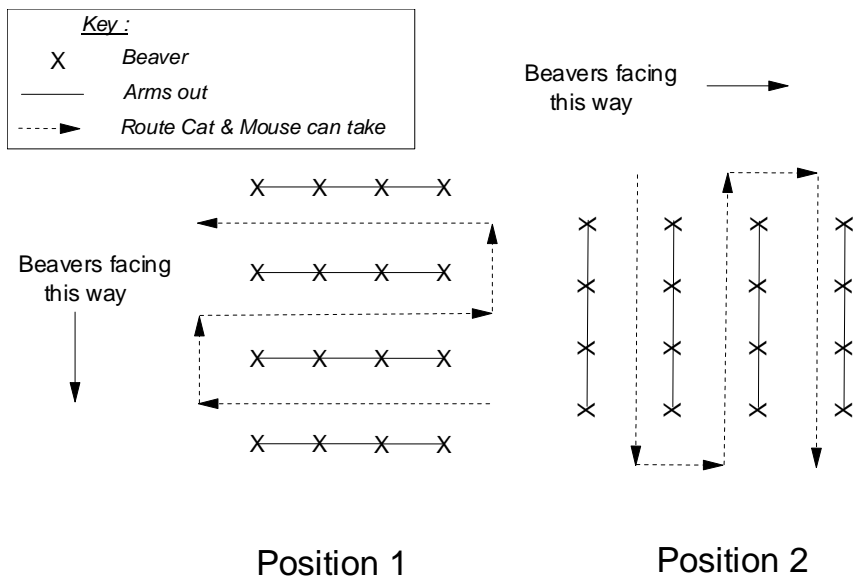

The Beavers are positioned in lines, arm distance apart. (Position 1) Arms are outstretched. A Cat and Mouse are chosen. The Mouse sets off running up and down the lines, the Cat in hot pursuit. The Leader shouts "TURN SIDE" and the Beavers all turn, keeping arms outstretched. This alters the position and direction of the lines. (Position 2) The Cat and Mouse now have to alter course. The chase continues until the Mouse is caught. The Beavers in the maze are told to "TURN FRONT" or "TURN SIDE" at frequent intervals.

*This game helps to improve the Beavers' capacity to listen and follow instructions quickly, and general co-operation within the Colony. It is a game where all the Beavers are involved for the whole time and so can join in the fun even when they are not the main players i.e. Cat and Mouse.*

*The Beavers initially find it confusing to position themselves in the lines as required. Some Beavers tend to run around the edges of the maze and have to be encouraged to run up and down. Instructions need to be precise and simple.*

---

## Super Stars            2 F

Equipment :        As required

Set up a series of bases with a Leader at each, running a different sporting event. Allocate the Beavers into Teams, the same number as you have bases. Blow the whistle after a set time period. Teams then go on to the next base. Events might include

- Target golf                - using a child's golf set, perhaps hitting the ball into hoops at varying distances
- Distance throwing        - using a tennis ball, or welly
- Penalties                 - kicking a football into a goal, using a Cub or Leader as goalkeeper
- Skipping                 - how many skips in a given time
- Target throwing         - throwing bean bags into hoops at varying distances
- Distance running        - number of circuits of a designated course

Can be played inside if weather is poor. Suggested changes / additions include :

- Penalties                 - with soft ball
- Skittle alley             - using plastic skittle set
- Target throwing         - throwing bean bags into chalked targets on the floor
- Standing long jump

*An ideal game for outside. Play for fun or allocate points at each base for performance achieved. Make sure that everyone knows which way round the bases they have to move when the whistle is blown. Care needs to be taken to ensure that the events take roughly the same time. Found that skipping is difficult to sustain interest. The other events can be extended by continuing to take turns until the time is up. The small groups make it easy to control. Groups can be chosen to minimise discipline problems.*

---